



Micrometrix™



Model SCM-1 STREAMING CURRENT MONITOR W/ INTEGRAL SENSOR

Features

- 4~20mA Output
- LED Display
- NEMA Enclosure
- Serviceable Sensor
- Zero Offset Function
- Sensitivity Adjustment
- Heavy Duty Motor

Precise Coagulant Dose Control for Water Treatment



Sensor Advantage

The Micrometrix™ SCM features a patented sensor design to provide years of trouble free service. The sensor probe is "user serviceable". The user can easily replace a disposable sleeve and piston within the sensor probe to restore accuracy and sensitivity. This approach drastically reduces the cost of ownership of an SCM.

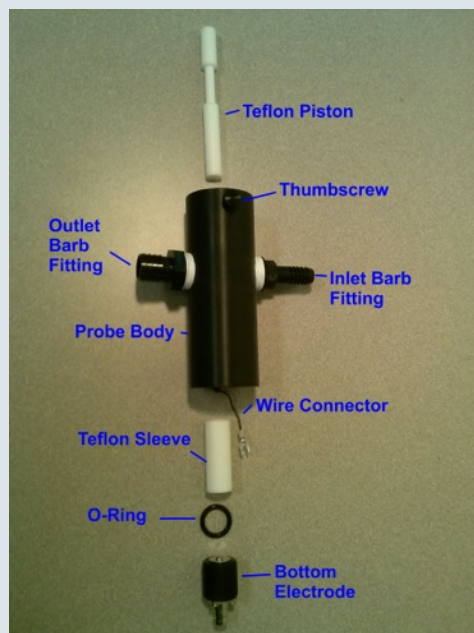

Patented

Benefits

- Chemical Savings
- Maintain Water Quality
- Early Warning Protection
- Prevent Upsets
- Optimize Treatment
- Reduce Residuals
- Easily Retrofitted



770.271.1330

micrometrix.com

contact@micrometrix.com

©Micrometrix Corp 2013

Engineering Specifications

The instrument shall be a complete streaming current measurement instrument for continuous monitoring and control of coagulant dosage to assist in optimizing the water or wastewater treatment process.

The instrument shall be a single module with integrated sensor and shall operate on 110VAC power. (optional 230 VAC)

The sensor shall receive a sample of treated water at a flow rate of 1 liter per minute. (optional 5 GPM) The sensor shall have a sample inlet of 1/2" and outlet of 3/4" barb style fitting. The sample probe shall be connected with a thumbscrew for easy removal without the use of tools for inspection or service. The probe housing shall use a disposable Teflon™ sleeve, which may be replaced independently of the electrodes. The upper and lower electrode shall be independently replaceable to facilitate easy servicing of the probe. The Sensor shall include two (2) spare probe piston / sleeves. Non-serviceable sensors and probe assemblies are not acceptable.

The monitor shall be housed in a non-metallic NEMA 4x housing suitable for mounting outdoors. The meter enclosure shall have a facility to use a lock, or tamper-resistant device, to prevent unauthorized use.

The monitor shall provide an LED digital display of the streaming current value calibrated in millivolts with a range of -1000mV to +1000mV. The meter shall have control functions for 1) meter zero adjustment 2) continuous sensor sensitivity adjustment 3) internal amplifier gain adjustment 4) self diagnostic flashing LED sensor operation indicator 5) independent high and low alarm contact set-point adjustments 6) High and low alarm LED indicators. The adjustment controls shall be recessed and require the use of a trimmer tool to minimize tampering by unauthorized personnel.

The instrument shall be a Streaming Current Monitor Model SCM-1 as manufactured by Micrometrix Corp.

Specifications	Model SCD-T
Measurement	Streaming Current
Power	110 Vac / 230 Vac (Optional)
Range	-1000 to +1000 mV
Accuracy	0.1%
Display Type	LED
Flow Rate	1 Liter/Min (Standard) or 5 GPM (Optional High Flow)
Connection Type	1/2" Barb In 3/4" Barb Outlet
Response Time	1 Second
Self Diagnostic	Sensor LED
Probe Materials	Delrin, 316 SS, PTFE
Outputs	4~20mA, -10 ~ +10 V, 0~10V
Communication	Modbus (Optional)
Alarms	High / Low Relay Contacts
Zero Adjust	Full Range
Enclosure	NEMA 4x, IP 65
Mounting Holes	11.0" x 6.00"
Weight	20 lbs , 9 kg

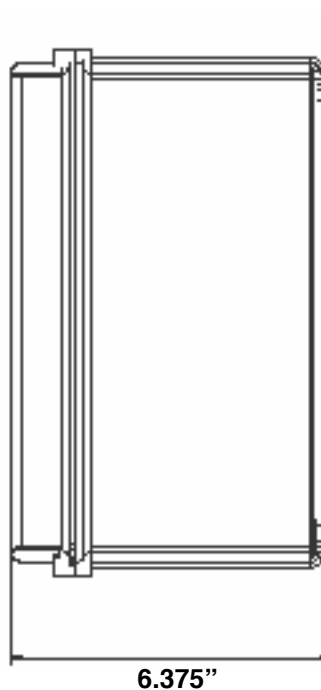
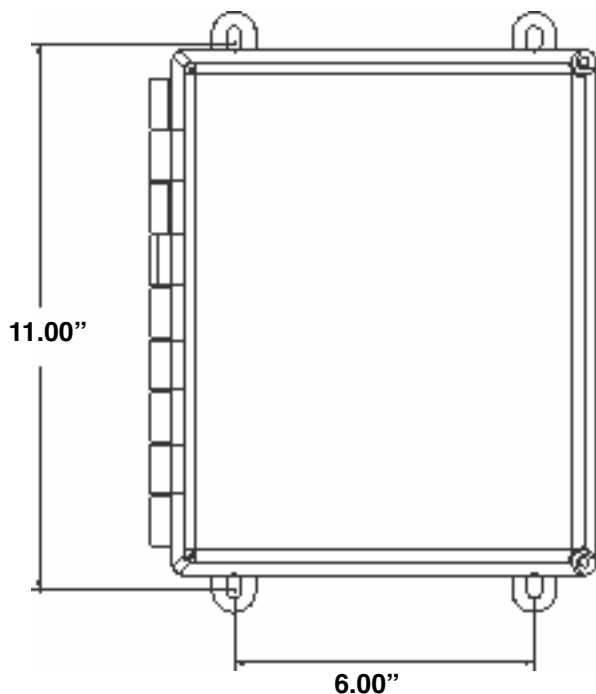

770.271.1330

micrometrix.com

contact@micrometrix.com

©Micrometrix Corp 2013