



Particle Charge Analyzer

Model PCA

Operating Manual



PCA Manual (PDF Copy)



Ph: 770.271.1330
Website: <http://www.micrometrix.com>
COPYRIGHT 2024
Rev: M January 2024

Direct Link: <https://micrometrix.com/wp-content/uploads/Particle-Charge-Analyzer-Manual-0124.pdf>

WARRANTY INFORMATION

Micrometrix® Corp warrants its equipment to be free from defects in material and workmanship for a period of one (1) year from date of shipment to the original purchaser. Upon receipt of written notice from purchaser, seller shall repair or replace the equipment (at option of Micrometrix® Corp.).

Micrometrix® assumes no responsibility for equipment damage or failure caused by:

1. Improper installation, operation, or maintenance of equipment.
2. Abnormal wear and tear on moving parts caused by some processes.
3. Acts of nature (i.e. lightning, etc.)

This warranty represents the exclusive remedy of damage or failure of equipment. In no event shall Micrometrix® Corporation be liable for any special, incidental, or consequential damage such as loss of production or profits.

SAFETY PRECAUTIONS

BEFORE ATTEMPTING TO UNPACK, SET UP, OR OPERATE THIS INSTRUMENT, PLEASE READ THIS ENTIRE MANUAL. MAKE CERTAIN THE UNIT IS DISCONNECTED FROM THE POWER SOURCE BEFORE ATTEMPTING TO SERVICE OR REMOVE ANY COMPONENT. FAILURE TO FOLLOW THESE PRECAUTIONS COULD RESULT IN PERSONAL INJURY OR DAMAGE TO THE EQUIPMENT.



CONTENTS

1. GETTING STARTED	1
1.1 Do Not.....	1
1.2 Do.....	1
1.3 Connection to your Main's Supply.....	1
2. SETTING UP THE INSTRUMENT	2
2.1 Connections to the PCA Control Unit.....	2
3. THE CONTROLS AND DISPLAYS	3
3.1 The Main Unit.....	3
4. PRINCIPLES OF OPERATION	4
4.1 Coagulant Demand Measurement (Water Treatment).....	4
4.2 Polyelectrolyte Titration (Papermaking).....	4
4.3 The Standard Polymers.....	4
4.4 The Streaming Current Measurement Cell.....	4
5. PERFORMING A TITRATION WITH THE STREAMING CURRENT CELL	7
5.1 Cleaning the SC Cell.....	7
5.2 Coagulant Demand Measurements (Water Treatment Applications).....	7
5.3 Preparing Stock Solutions.....	7
5.4 Polyelectrolyte Titration Steps – (Papermaking Applications).....	8
5.5 Calculation of Charge in Microequivlents/Liter (Anionic Sample).....	9
5.5.1 Finding the Ratio Factor of the Polymers.....	10
5.6 Alternate Titration Method for Interfering Cationic Samples.....	10
5.7 Calculation of Charge in Microequivlents/Liter (Amphoteric Sample).....	11
5.7.1 Example.....	11
5.7.2 Example.....	11
6. HELPFUL INFORMATION	12
6.1 The End Point.....	12
6.2 Limitations of the PCA.....	12
6.3 Effects of pH on the Titration and Calculation of the Correction Factor.....	12
7. CALCULATION OF CHARGE (IN MICROEQUIVALENTS/LITER)	13
8. APPENDIX I	14
8.1 Preparation of the Standard Polymers.....	14
9. APPENDIX II	15
9.1 Example Calculation of the Charge Density of Cationic Sample.....	15
10. APPENDIX III	15
10.1 Example Determination of the Charge Demand of Paper Stock.....	15

1. Getting Started

Thank you for purchasing Micrometrix® equipment. Please ensure that you have read and understood this operating manual before use. Store this manual in a safe place for future reference.

1.1 DO NOT

- Do not plug into your local mains supply until you have checked that your local supply voltage matches that stated on the label at the rear of the instrument (adjacent to the mains inlet connector).
- Do not change the fuse or remove any covers with the mains inlet lead connected to the unit.

1.2 DO

- Do ensure that if the molded plug is removed from the mains inlet lead it is disposed of safely.
- Do read and understand this manual before use.

1.3 Connection to your Main's Supply

****IMPORTANT**** This unit must be earthed to ensure operator safety. The mains inlet lead may have a molded plug fitted that is not suitable for connection to your local supply. If it is necessary to remove this plug and fit a suitable one, the removed plug must be safely disposed. The removed plug would present a serious shock hazard if plugged into a suitable supply with the bare wires exposed.

The wires of the mains inlet lead are colored as follows:

GREEN	EARTH
WHITE	NEUTRAL
BLACK	LIVE

As the colors of the wires in the mains lead may not correspond with the colored markings identifying the connections in your plug, proceed as follows:

1. The wire colored **GREEN** must be connected to the terminal in the plug marked with the letter **E** or the earth symbol or colored **GREEN**.
2. The **WHITE** wire must be connected to the terminal marked **N** or colored **WHITE**.
3. The **BLACK** wire must be connected to the terminal marked **L** or colored **BLACK**.
4. Before connecting the unit to the local power supply, it is important to ensure that the voltage selector switch on the rear panel is set to suit your local supply voltage.

Before changing a fuse, switch off the mains supply and disconnect the mains inlet lead from the instrument.

If the power plug is a fused type, it should be fitted with a 1A fuse.

The unit contains no user serviceable parts. The cover should only be removed by competent personnel (after first switching off the power supply and disconnecting the mains inlet lead).

For any servicing or repairs, the unit should be returned to the manufacturer with a covering letter. Please ensure the unit is carefully packaged to avoid damage during shipment.

2. Setting up the Instrument

The main parts of the PCA Particle Charge Analyzer are as follows:

- The PCA main unit. This is the main box containing the electronics and the power supplies, display, etc. for the instrument.
- The Streaming Current Measurement Cell (SCMC). This is the white chamber, which incorporates the SC cell, and piston.
- Power cord.
- BNC connector for connecting to an optional automatic titrator or data logger.

2.1 Connections to the PCA Control Unit

The connections for the PCA main unit are made via connectors on the rear panel. The numbers below refer to the labels in Figure 1:

1. The power supply inlet connector should have the local power supply lead plugged into the bottom.
2. The fuse holder is located on the rear panel.
3. The millivolt output BNC connector enables the main unit to be connected to optional automatic titrator or data logger which accepts a -1000 mV to +1000 mV signal. Any standard BNC to BNC cable is suitable to connect your PCA to the titrator or data logger.

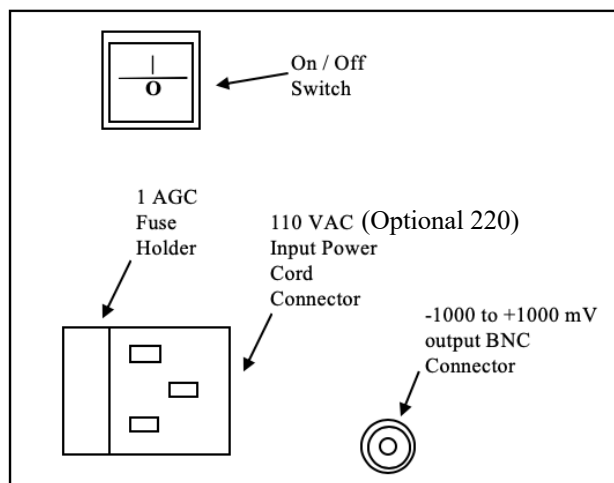

Figure 1 – The Rear Panel of the PCA

3. The Controls and Displays

There are two controls for the PCA 1) The *Sensitivity adjustment* and 2) *ZERO adjustment* which are both located on the front panel. A trimmer tool or small screwdriver is used to adjust the controls. The controls are 10-turn potentiometers which allows the user to control the gain and zero adjustment of the signal processor. The sensitivity control may be useful when samples of various conductivity may require a more or less sensitive response on the display reading or output. **This control has no impact on the polarity (cationic/anionic sign)** of the measurement. The conductivity of the sample may also be adjusted by adding deionized water to the sample.

The Zero offset control is active when the switch is pressed, and the yellow LED is lit. The zero trim pot allows the user to adjust the display for a desired endpoint or calibrate the instrument to a “Zero” value for a charge neutral sample such as pH buffer 7 solution.

The LED display indicates the relative charge value of the sample. A *negative reading* indicates an **Anionic** sample and a *positive reading* indicates a **Cationic** sample. There are also two corresponding colored LEDs which indicate the polarity or sign. The total amount of titrant divided by the sample volume determines the “charge demand” of the sample. This result must also be multiplied by the strength of the titrant to calculate the milli-equivalents of charge for the sample.

The PCA may be used with an automatic titrator to perform the automatic titrations of the sample. When the charge analyzer is connected to an Automatic titrator, the mV output signal at the rear of the charge analyzer is used to determine the endpoint. Typically, an endpoint of zero volts (isoelectric) is programmed into the Automatic Titrator. The Automatic titrator will slow the titration procedure as the charge analyzer mV value (charge) approaches zero, so as to minimize overshoot. The auto titrator will then calculate the precise volume of titrant used to reach the endpoint. If the sample is anionic the amber LED will automatically be extinguished, and the red LED will illuminate when the sample reaches cationic.

When manually titrating anionic samples with a standard cationic polyelectrolyte, the *DOSING LED* is an amber LED and is illuminated while the sample is still anionic. The manual titration is completed when the *TITRATION END LED* (red LED) and illuminates indicating the sample is cationic. It is then important to note the amount or volume of titrant used to bring the sample to Zero charge. The LED display may continue to drift in the positive direction.

- Manual titrations should be performed slowly and stepwise to minimize overshoot.
- The measurement cell and piston should be cleaned and rinsed between titrations.
- IF the dosed titrant volume equals more than 10% of the sample volume without finding an end point, it is recommended to use a stronger concentration of titrant or dilute the sample with DI water.

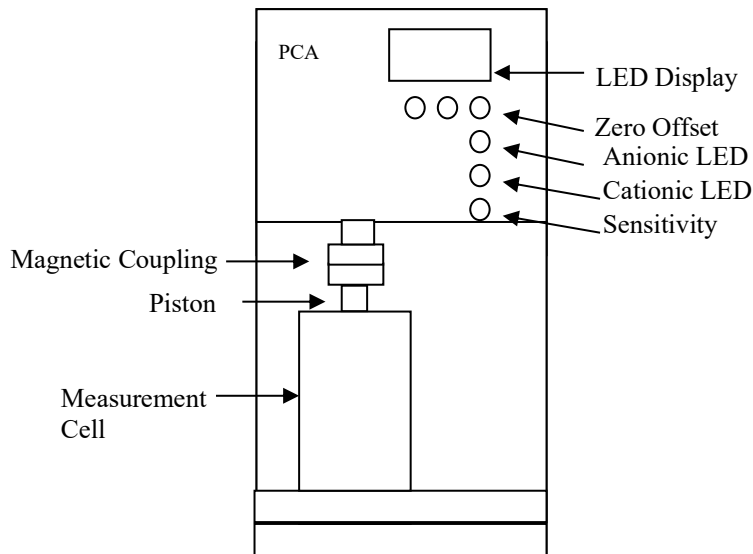

Figure 2 – PCA Front View

4. Principles of Operation

The PCA measures colloidal and ionic charge in liquid samples. The instrument is used to determine anionic or cationic levels. A digital readout provides a convenient reference for the user to know the charge value of the sample. The instrument can be used with automatic or manual titration to quantify the charge demand in milli-equivalents per ml. The instrument is designed to test liquids and suspensions of small colloidal particles. Samples containing very large particles and long fibers will need to be screened, to remove particles larger than 100 microns, prior to measurement. An automatic titrator can be connected to the millivolt output of the PCA and be used to perform fully automatic cationic or anionic titrations where zero mVolts is the endpoint.

4.1 Coagulant Demand Measurement (Water Treatment)

The principle of coagulant charge demand measurement is based on the fact that raw (surface) water has anionic colloidal particles which are stabilized and must be destabilized through charge neutralization for coagulation and flocculation to occur. The PCA indicates the relative degree of neutralization as positively charged chemicals (coagulants) are added to the sample. The theoretical optimum endpoint is “zero” mV, but most plants run slightly above or below zero because of the unique process dynamics for a given plant. The starting point to determine the “best charge endpoint” to run the plant is to mimic the current plant dosage when the plant is producing acceptable water.

4.2 Polyelectrolyte Titration (Papermaking)

The principle of polyelectrolyte titration is based on the fact that the standard polymers chosen form 1:1 compound with each other in relation to their charge, therefore corresponding to an acid/base neutralization thus:

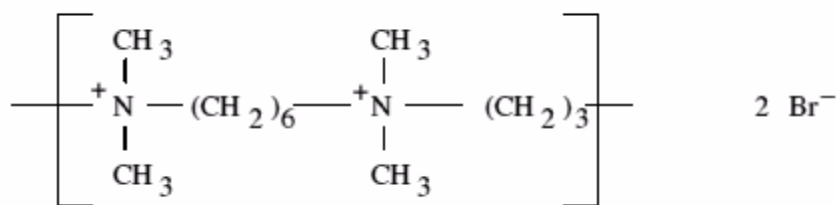

In acid/base titration the acid or base content of an unknown sample is determined by consumption of a standard base or acid, as appropriate, until the point of neutrality is reached. In polyelectrolyte titration a standard anionic or cationic polymer is titrated with an unknown sample until a point of zero charge is reached.

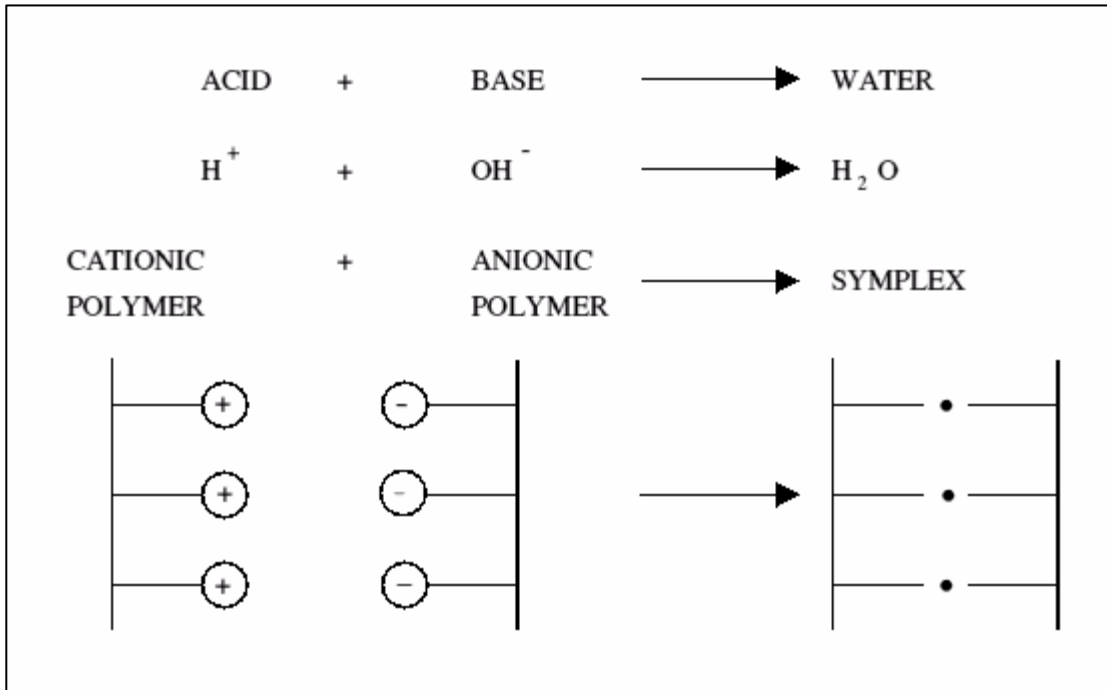

4.3 The Standard Polymers

The standard polymers recommended for use in the titration are Potassium Polyvinyl Sulphate and PolyDADMAC:

- Potassium Polyvinyl Sulphate (PVSK) is used as the standard anionic polymer and the molecular weight of the monomer is 162.

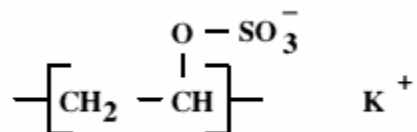

- PolyDADMAC is used as a standard cationic polymer the molecular weight of the monomer is 161.5.
- Hexamethrine Bromide (Polybrene) can also be used as the standard cationic polymer and the molecular weight of the monomer is 374.

4.4 The Streaming Current Measurement Cell

The Streaming Current cell (SC cell) determines the charge of the sample and hence the end point of the titration. The cell (see Figure 4) consists of a precision bore cylinder closed at the bottom end and containing two electrodes, one at the bottom, and one approximately a third of the way up. The electrodes are connected to the contacts extending from the lower front portion of the instrument housing. The measurement cell is designed as a container to allow sample to be poured in from the top. The typical sample volume is 100ml.

A precision piston oscillates up and down in the cylinder with a frequency of approximately 4hz. Polymers, having a tendency to absorb onto interfaces, become attached to the piston and cylinder walls. The mobile counterions of the fixed electrolyte are carried away in the liquid stream creating an electric current due to the partial charge distribution measured between the two electrodes. This electric current is measured by the electronics in the main unit and used to determine the titration.

Since the polymers adhere to both the piston and cylinder walls during a titration the accuracy of the titration is dependent on the cleanliness of the cell and the operator's ability to remove all traces of the previous sample between titrations (see Section 5).

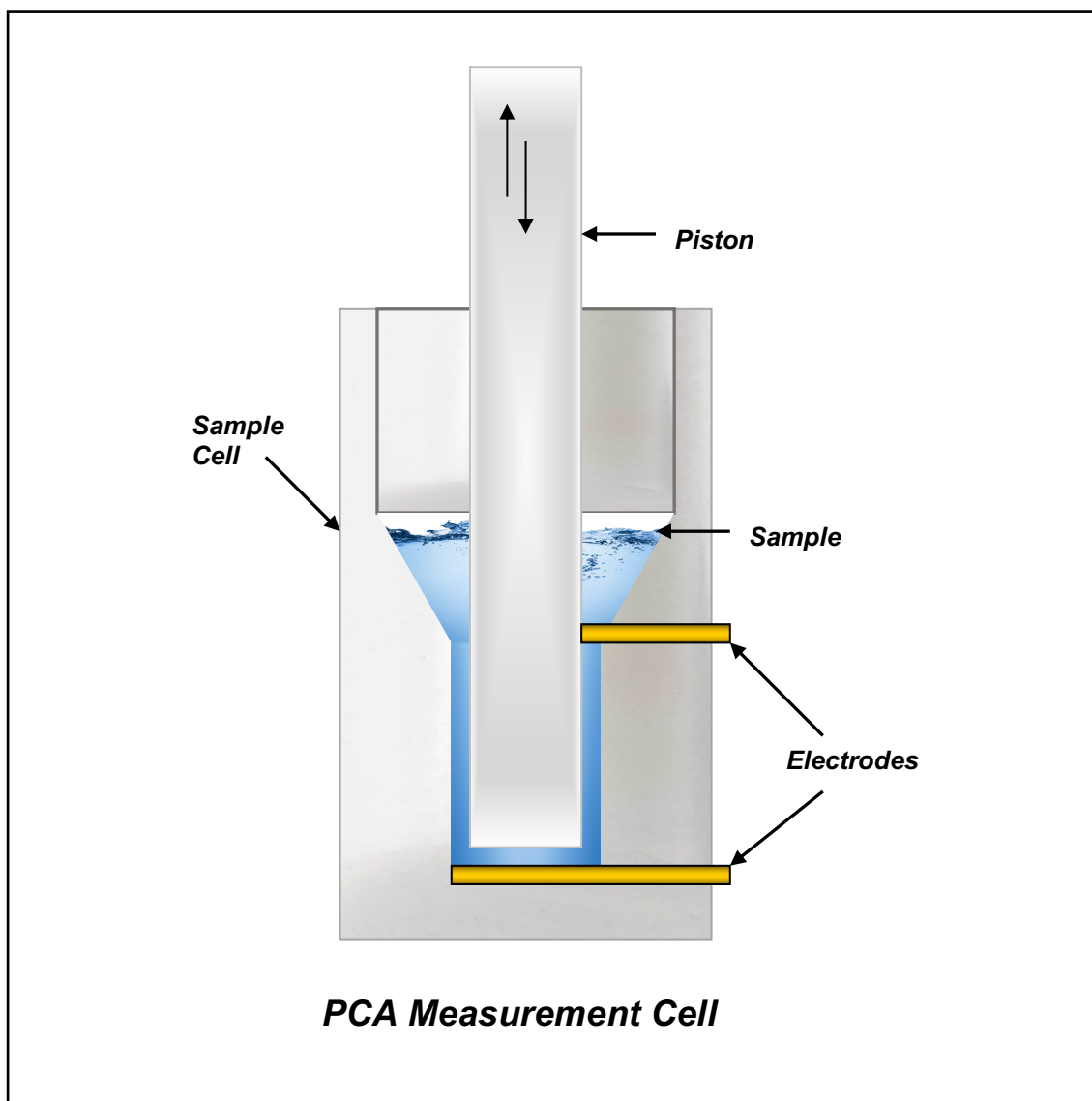

Figure 3 – Streaming Current Detector Cell

5. Performing a Titration with the Streaming Current Cell

5.1 Cleaning the SC Cell

Before starting a titration, it is extremely important that the cell is completely clean to ensure that any sample or polymer from a previous titration is removed. Cleanliness of the cell will ensure good repeatability and accuracy of titrations and should be carried out after every titration. The following cleaning procedure may be found helpful:

1. Remove the cell from the main unit by sliding the cell forward on the “dovetail” guide at the base.
2. The cell and piston should then be brushed vigorously under running water using a stiff test tube cleaning brush. It will not damage the cell to completely immerse in water.
3. For thorough cleaning, the cell should then be brushed out with a dilute solution of household bleach (about 10% bleach in water) for about 20 seconds.
4. Finally flush out with tap water. Do not leave the cell filled with bleach as this may affect the stainless-steel electrodes. The outside electrode contacts should be wiped dry with a towel.
5. Replace the piston and the cell can now be refitted to the main unit by sliding the cell until it is fully pushed against the lower contacts. The piston assembly will automatically attach as the upper and lower magnets come in close proximity.

5.2 Coagulant Demand Measurements (Water Treatment Applications)

For best results, here is a simple guide to using the PCA. Prepare a stock solution of chemical and mimic the current plant dosage into 100ml of Raw water to determine a “target endpoint” for future tests. This is the starting point to determine the “best charge” to run the plant. This endpoint is used during changing plant conditions to quickly determine dosage.

To perform a test:

1. Rinse the cell with Raw water as a conditioning step prior to a test.
2. Add stock solution slowly to 100mL Raw water until you reach the “endpoint.”
3. Calculate the plant dose based on the volume and strength of coagulant (titrant) used.

The theoretical optimum endpoint is “zero” mV, but most plants run slightly above or below zero because of the unique process dynamics for a given plant.

5.3 Preparing Stock Solutions

The following equation is used to calculate the Stock Solution Concentration:

Stock Solution Concentration (%) =

$$\frac{\text{Desired Dosage (mg/L)} \times \text{Volume of Raw Water (mL)}}{\text{Amount of Stock Solution added to each jar (1 mL)} \times 10,000 \text{ (mg/L to \% conversion factor)}}$$

The following equation is used to determine the product volume:

$$\text{Product volume (mL)} = \frac{(\% \text{ solution}) \times (\text{flask volume, mL}) \times (8.34 \text{ lb/gal})}{100 \times (\text{product strength, lb/gal})}$$

Determining the product strength of liquid chemicals

To determine how much liquid chemical you must use to prepare the stock solution, you must first determine the product strength. Product strength is the actual (reactive) chemical that is contained in each gallon of liquid. To determine the product strength, you must know the product specific gravity and percent concentration. For example, liquid alum has a product specific gravity of 1.35 and a percent concentration of about 48%.

Product specific gravity and percent concentration can be determined from the product supplier and product information sources such as MSDS. Once the product specific gravity and percent concentration are known, Table 1 can be used to determine the product strength.

	Alum
Product Strength (%)	48.0%
Specific Gravity	1.325
Product Strength (lb/gal)	5.30

Table 1 – Example for Product Strength

5.4 Polyelectrolyte Titration steps – (papermaking applications)

1. Fill the measurement cell with 100mls of sample. Optionally, a known volume of sample could also be added to the deionized water in the cell to bring the total volume of sample to 100ml. This would normally be between 10ml and 100ml depending on the sample. It should be noted that while larger volumes of sample will theoretically give a more accurate titration, higher concentrations of sample may not give a satisfactory titration. Providing the titration requires at least 1ml of standard polymer to reach an end point then reasonable accuracy should result.
2. Make sure the cell is fully pushed against the lower contacts and piston assembly moves freely within the measurement cell. Connect the power cord to the main unit of the PCA and to your local supply voltage. Connect the BNC output if using an Automatic Titrator.
3. Switch on the PCA main unit. The PCA will turn on the anionic or cationic LED and the display will show the initial charge value reading. The sensitivity “10 turn” potentiometer may be adjusted to the desired signal amplification. Zero turn setting is the minimum amplification. A ten-turn setting is the maximum amplification.
4. Allow the sample to stabilize for 30 seconds to one minute. If the reading is fluctuating after one minute, this may be an indication the cell was not thoroughly cleaned. Simply discard the old sample and replace with fresh sample. The mV reading refers to the value of the charge. For best results, fill the sample cell with 100mls of “conditioning sample”, allow time for reading to stabilize, discard conditioning sample and then fill the sample cell with 100mls of the sample to be titrated.
5. Refer to the Automatic Titrator manual for further information and instructions for mV endpoint titration.
6. For manual titrations: hold a pipette or syringe over the cell and carefully add titrant into the liquid between the moving piston and the cell wall. The piston action will ensure the sample is kept adequately mixed during the titration.
7. Wait 20 to 30 seconds to observe the response to incremental dosages of titrant.

8. The display will indicate the value of the charge from the cell, with negative values indicating the sample is anionic and positive values indicating the sample is cationic. Continue to add titrant until the value reaches zero. Note the titrant volume used to bring the reading to zero. Use this volume of titrant required for your calculations. If the cell is completely clean the charge value will be somewhere below –500 with distilled water. Indications of a dirty cell may be a positive reading, which is probably residual polymer from a previous titration. Various factors determine this initial charge value e.g. quality of the water, motor speed, cell wear etc. Providing that the value is stable and does not start positive with distilled water, then it can be assumed that the cell is clean, and a titration can then be started. If there is any doubt, then it would be wise to re-clean the cell and start with a completely fresh sample of distilled water and compare the charge values.
9. The pH of the sample should now be noted in case a correction factor is required for the charge calculation (see Section 7), and also the charge value. If the sample is anionic (the charge reading is negative) a precise volume of standard cationic polymer should be added (normally 2 - 5ml of PolyDADMAC) so that the charge reading will be zero or slightly positive. If the sample is cationic (the charge reading is positive) a precise volume of standard anionic polymer should be added (normally 2 - 5ml of PVSK) so that the charge reading will be at zero or slightly negative. The addition of a precise volume of standard polymer is easily carried out. The titration will now continue with the charge value dropping towards zero. The charge should then reverse as the reading passes through zero. When using an Automatic Titrator, the last amount dosed will be different to the end point dose as the automatic titrators always titrates past the end point.
10. The end point dose value above should be noted along with the pH value, these are used in the calculation of the quantitative value of the charge of the sample.
11. The cell can now be cleaned, and a further titration carried out if required.

5.5 Calculation of Charge in microequivalents/liter (Anionic Sample)

The equation used to calculate the charge of an anionic sample is as follows:

$$\text{Charge (equiv./l)} = \frac{(\text{CP}) \times \text{N}}{\text{V}}$$

Where:

CP = volume of cationic PolyDADMAC (ml)
 V = volume of test sample (ml)
 N = normality of the PolyDADMAC

The formula for the calculation of the charge of Cationic sample is as follows

$$\text{Charge (equiv./l)} = \frac{(\text{AP}) \times \text{N}}{\text{V}}$$

Where:

AP = volume of anionic PVSK (titre value)
 N = normality of the PVSK
 V = volume of test sample

5.5.1 Finding the Ratio Factor of the Polymers

Both standard polymer solutions should have been accurately made up to 0.0005N. (PVSK is taken to be the main standard and the PolyDADMAC concentration is adjusted to equate to the PVSK, at pH 7.)

It is unlikely that the PVSK and PolyDADMAC are exactly the same strength and so, the PVSK: PolyDADMAC ratio will not be 1:1. Under certain circumstances, such as different pH or water conditions this difference will be exaggerated. We therefore need to include a factor in the calculation to allow for this deviation.

With each series of tests, a blank titration must be included, i.e. Titrate 5ml PolyDADMAC with PVSK and record the result.

e.g. assume 5ml PolyDADMAC is titrated with 4.850ml PVSK.

Here the PolyDADMAC is weaker than the PVSK and would need to be multiplied by a factor of:

$$\frac{4.850}{5.000} = 0.970$$

All PolyDADMAC amounts should be multiplied by the factor obtained from the blank titration.

5.6 Alternate Titration Method for Interfering Cationic Samples

There may be certain cationic samples that interfere with the PCA cell causing problems during a titration. If this does occur, then it may be advantageous to modify the procedure as follows:

- a) Prepare the PCA for a titration in the usual way checking the cleanliness of the cell with a sample of distilled water.
- b) In a separate beaker add a known quantity of sample as usual then add 5ml of PVSK. Mix the two liquids then add 50ml of distilled water.
- c) Add the sample to the measurement cell and attach cell to the main unit. Titrate as normal using PolyDADMAC. (N.B. the charge value should start highly negative.)

This alternative Back Titration Method allows the PVSK to complex with the cationic sample before it can absorb onto the cell walls and may produce a more reliable titration. For amphoteric samples, the back-titration method allows neutralization of both anionic and cationic constituents. This category may include paper mill samples with high levels of cationic polymers.

(Note: it is important that a blank titration is first carried out to determine the ratio of PVSK to PolyDADMAC, see Section 6.6.)

A known amount of sample, prefiltered in the case of those taken from paper mills, is added to the sample cell cup containing the distilled/deionized water. When evaluating paper stock filtrates, one would normally use between 100ml and 50ml of sample (accurately pipetted). Under certain circumstances, such as a heavily contaminated sample, it may be necessary to use only 10ml to 50ml diluted into 50 to 90 mls of DI water. The larger the sample, the more accurate the result of the titration; but heavy contamination may interfere with the test and therefore a reduction in sample size is necessary to achieve a meaningful result. **10**

The addition of an accurate amount of the standard anionic polymer, 0.0005N PVSK, should be made. The required quantity of PolyDADMAC dose would normally be between 2ml and 5ml. Then titrate with PolyDADMAC into the sample cell so that it feeds into the test solution. Continue to add PolyDADMAC until the reading reaches zero. It is the end point dose volume that is used in the calculation.

5.7 Calculation of Charge in microequivalents/liter (Amphoteric Sample)

The equation used to calculate the charge of an amphoteric sample is as follows:

$$\text{Charge (equiv/l)} = \frac{(\text{CP}) - (\text{AP} \times \text{F}) \times \text{N}}{\text{V}}$$

Where:

AP = volume of anionic PVSK (titre value)
 CP = volume of cationic PolyDADMAC
 N = normality of the titrant standards
 F = Factor (see Section 5.3.1)
 V = volume of test sample

Example

20ml of sample diluted into 80 ml of DI water and 5ml of PVSK (factor 0.97) were titrated with 2.642ml. of PolyDADMAC

$$\begin{aligned} \text{Charge} &= \frac{(2.642) - (5 \times 0.97) \times .0005}{20} \\ &= -55.2 \mu\text{equiv/l} \end{aligned}$$

N.B. the calculated value must be negative for an anionic sample.

Regarding the sample size for an anionic product (chemical), the recommended amount would be 1ml of a 1g/l solution. For the calculation, the volume of the test sample would be taken as 1.00 and the answer converted to milliequiv/g (not $\mu\text{equiv/l}$).

Example

1.00g of a 1g/l solution of unknown anionic polymer and 5ml of 0.0005N PVSK were titrated with 4.116ml 0.0005N PolyDADMAC, at pH 7.

Using the same equation:

$$\begin{aligned} \text{Charge} &= \frac{(4.116) - (5 \times 1.00) \times .0005}{1.00} \\ &= -442 \mu\text{equiv/g} \\ &= \frac{-442}{1000} = 0.442 \text{ milliequiv/g} \end{aligned}$$

This value would be called the charge density of the product at pH 7. It must be remembered that this value changes with respect to pH. When comparing chemicals, they must all be assessed at the same pH.

6. Helpful Information

6.1 The End Point

An automatic titrator will titrate the sample until the phase of the charge has changed sign (and thus the charge value of the sample has changed sign, however there is typically some overshoot). The endpoint dose is calculated by subtracting the overshoot dosage and then displayed; this value is the dose when the charge was at a minimum value.

6.2 Limitations of the PCA

It is important to realize that the PCA may not be able to titrate all samples, especially those with conductivity over 35 millisiemens and those that the standard polymers are not able to neutralize the charge of. If the conductivity is too high it may be possible to dilute the sample into a larger quantity of deionized water.

6.3 Effects of pH on the Titration and Calculation of the Correction Factor

The amount of PVSK required to neutralize a given amount of PolyDADMAC varies with the pH of the sample and thus a correction factor for any pH needs to be determined. For any given volume of PolyDADMAC, slightly more PVSK is required in the acid region and slightly less in the alkaline region.

The PVSK is accurately prepared to 0.0005N and is used as the standard reference polymer. It is unlikely that the two standard polymers have been mixed to exactly equal strengths (see Appendix I), and thus a titration would be required to determine a correction factor for the PolyDADMAC. It is easy at this stage to produce a correction factor for a range of pHs and the correction factor used in the charge calculation. To calculate this correction factor simply titrate a sample of 5ml PolyDADMAC in distilled water against PVSK. This titration should be carried out at a range of pH values, with the mean dose of two titrations for each pH being used to ensure greater accuracy. The correction factor is the ratio of the amount of PVSK dosed to the amount of PolyDADMAC (in this case the end point dose divided by five).

A graph of pH (y-axis) against correction factor (x-axis, PVSK/ml of PolyDADMAC) is plotted and this should be close to a straight line. The correction factor for any pH can then be obtained. It should be noted that this graph would only be valid for the standard polymers used, and a new set of data would need to be plotted every time a fresh quantity of either polymer was prepared. The correction factor may also vary slightly from one sample of distilled water to another depending on the quality of water. The correction factor is for the PolyDADMAC (the PVSK being the reference standard) and is used to correct the actual volume of PolyDADMAC titrated.

7. Calculation of Charge (in microequivalents/liter)

The calculation of charge is based on using PVSK made up exactly to 0.0005N, as the reference standard for the titration (see Appendix I for information about preparation of the standard polymers). If the PolyDADMAC has also been accurately prepared then at pH 7 the two polymers will titrate in deionized water in a 1:1 ratio, i.e. 5ml of PVSK will exactly neutralize 5ml of PolyDADMAC. However, as pH affects the titration (see Section 6.3) it is not essential that the PolyDADMAC is exactly 0.0005N as the calculation includes a correction factor to take into account the effects of pH, the inaccuracy of mixing the PolyDADMAC and the quality of the distilled water. It is important that when the instrument is used in the field with unknown distilled water, a series of titrations should be carried out to determine a correction factor for the water used, or at least to check that a previous factor is correct with this particular sample of water.

By definition a sample has an equivalence of one per liter if one liter of the sample exactly neutralizes the charge of one liter of 1N PVSK.

The formula for the calculation of the charge of an unknown sample is as follows:

$$\text{Charge (equiv./l)} = \frac{(\text{AP} - \text{CP}) \times \text{N}}{\text{V}}$$

Where:

AP = volume of anionic PVSK (ml)

CP = volume of cationic PolyDADMAC (ml) x correction factor

V = volume of test sample (ml)

N = normality of the PVSK

N.B. although AP, CP and V are in ml the charge is still in equiv./l as the scaling factors cancel in the above formula.

Example

20ml of sample and 5ml of PolyDADMAC were titrated with 2.387ml of 0.0005N PVSK. At the pH of the sample the correction factor for the PolyDADMAC was 0.967

$$\begin{aligned} \text{Charge} &= \frac{2.387 - (5 \times 0.967)}{20} \times 0.0005 \\ &= -0.0000612 \text{ equiv./l} \\ &= -61.2 \text{ microequiv./l} \end{aligned}$$

N.B. the Charge value will be negative for an anionic sample and positive for a cationic sample.

8. Appendix I

8.1 Preparation of the Standard Polymers

The two standard polymers recommended are Potassium Polyvinyl Sulphate (PVSK) as the standard anionic polymer, and (PolyDADMAC) as the standard cationic polymer. Both PVSK and PolyDADMAC are available from Aldrich Chemicals (with PVSK also being available from Eastman Kodak, USA). It is recommended that PVSK is used as the reference standard and is mixed to exactly 0.0005N. The PolyDADMAC is then prepared to as near as possible 0.0005N, although any slight inaccuracy of the strength of the PolyDADMAC can be offset using the correction factor determined in Section 6.4.

It is possible to purchase standard Hyamine 1622 (Benzethonium Chloride) solution precisely prepared to 0.004M, which is used as a standard cationic solution. The PVSK is then prepared; titrating it against the Hyamine to ensure it is exactly 0.0005N. Unfortunately, the Hyamine is of low molecular weight; it is not possible to use the PCA to perform the titration against the PVSK. However, it is possible to manually titrate the Hyamine against the PVSK using Toluidine Blue as an indicator, which turns from blue to pink in the presence of anionic polymers. It is necessary to know the purity of the sample of PVSK, if this is known it should be possible to exactly mix a 0.005N solution without performing a titration with Hyamine. However, for a sample of unknown purity or as a double check of the strength, a titration should be performed.

To prepare the PVSK and PolyDADMAC solutions proceed as follows:

- a) Weigh out $(1.62 \times 100 / \text{percentage purity})$ grams of PVSK solid (if the purity is unknown assume 95%, i.e. use $(1.62 \times 100 / 95)$ or 1.705g of PVSK).
- b) Make up a solution of this PVSK in 1000ml of distilled water giving a concentration of 0.01N.
- c) Take 50ml of this 0.01N solution and make it up to 1000ml with distilled water giving a concentration of 0.0005N.
- d) Take 100ml of distilled water in a 250ml beaker and add 0.1ml of a 0.1% solution of Toluidine Blue O as the indicator.
- e) Titrate this sample using the 0.0005N solution of PVSK until the indicator just turns pink and note the volume used. The indicator itself consumes about 0.8ml PVSK to be neutralized.
- f) Repeat steps d) & e) this time adding 1ml of the 0.004M Hyamine to the titration sample and again note the volume of PVSK consumed.
N.B. the titrations in steps e) and f) are easily carried out with an automatic titrator mode slowing the dose rate down towards the end point.
- g) The difference between the volume of PVSK used in the two titrations in steps e) and f) is the volume of PVSK needed to complex the Hyamine and should be exactly 8.0ml if the PVSK is exactly 0.0005N.
- h) If the volume of PVSK titrated is not 8ml then the strength of the PVSK should be adjusted to give a solution of exactly 0.0005N. If the solution is already too dilute it will be necessary to repeat step c) but calculate the volume of distilled water required to give the correct dilution.

- i) We now have a PVSK solution of exactly 0.0005N and this is used as the reference standard polymer for all titrations.
- j) To make up the PolyDADMAC solution, weigh out approximately 1.9g of PolyDADMAC and make up a solution with 1000ml of distilled water to give a strength of about 0.01N.
- k) Take 100ml of this solution and make up to 1000ml with further distilled water to give a solution of approximately 0.001N.
- l) 2ml of this solution can now be titrated in distilled water against the reference standard PVSK, using the PCA. If the PolyDADMAC is exactly 0.001N then 4ml of PVSK will be required.
- m) From the titration, the volume of distilled water required to dilute the PolyDADMAC to 0.0005N can be calculated, and this volume used to produce the standard PolyDADMAC solution.
- n) Any minor inaccuracies in the strength of the PolyDADMAC are not important and a correction factor needs to be found to accommodate this error (along with the errors occurring due to pH and the quality of the distilled water used) (see Section 6.3).

9. Appendix II

9.1 Example Calculation of the Charge Density of a Cationic Sample

The recommended procedure to calculate the charge density of an unknown cationic product would be to first mix up a solution of 1g per liter of product and then titrate 1ml of this solution.

EXAMPLE:

1.0ml of a 1g/l solution of unknown polymer is added to 5ml of 0.0005N PVSK and titrated with 3.482ml of 0.0005N PolyDADMAC. The pH was 7 and the correction factor of the PolyDADMAC 0.979. Using the formula for the calculation of charge (see Section 7) the volume of the test sample would be 1ml and the result would thus be in milliequiv/g.

$$\begin{aligned} \text{Charge} &= \frac{(5 \times 0.979) - 3.482}{1.00} \times 0.0005 \text{ equiv} \\ &= 0.707 \text{ milliequiv/g} \end{aligned}$$

This value would be called the charge density of the polymer at pH 7. N.B. it must be remembered that this value is dependent on the pH of the sample and thus when comparing different chemicals their charge densities must all be measured at the same value of pH.

10. Appendix III

10.1 Example Determination of the Charge Demand of Liquid / Colloidal Phase of Paper Stock After addition of Cationic Promotor

This charge analyzer technique has been designed to measure liquid and colloidal phase of samples (or ones with low concentrations of small particles) and thus a paper stock sample will need to be filtered or screened prior to carrying out a titration. Filter paper should not be

used, as cationic samples will absorb onto the paper giving erroneous results. Glass fiber filter pads are recommended as the best medium (for example a Whatman GF/C grade or similar) with a particle retention of 1.2 microns (for colloidal charged particles) and above. It is advisable to discard the first few ml of filtrate. A titration on the filtrate can now be carried out in the normal way remembering to check the pH of the sample to obtain the correction factor of the PolyDADMAC. Most paper stock samples show anionic activity and it is useful to know the cationic demand, this being defined as the amount of cationic charge required to reduce the sample to the isoelectric point. An effective way to find this cationic demand is as follows:

- a) Take 5 x 200g samples of stock.
- b) Stir in five different concentrations of a Cationic Promoter (Anionic Scavenger) product one concentration to each sample e.g. 0.1%, 0.2%, 0.3%, 0.4% and 0.5% of Cationic Promoter by weight of dry stock.
- c) After 2 minutes stirring, filter all five samples and titrate each in turn to calculate their charge.
- d) Plotting a graph of Cationic Promoter versus charge enables the extent of neutralization to be readily examined.

This method gives a good guide as to the best substance to use for combating interfering substances and also the most suitable dosing level to use.

****NOTE**** Cationic Promoter / Anionic Scavenger is a term for a range of cationic chemicals used for the neutralization of anionic interfering substances in paper.