

Model SCD-T STREAMING CURRENT DETECTOR W/ TRANSMITTER 6TH GEN SENSOR

Features

- ▶ 4~20mA Output
- ▶ NEMA Enclosure
- ▶ Serviceable Sensor
- ▶ Zero Offset Function
- ▶ Sensitivity Adjustment
- ▶ Heavy Duty Motor

Precise Coagulant Dose Control for Water Treatment



Sensor Advantage

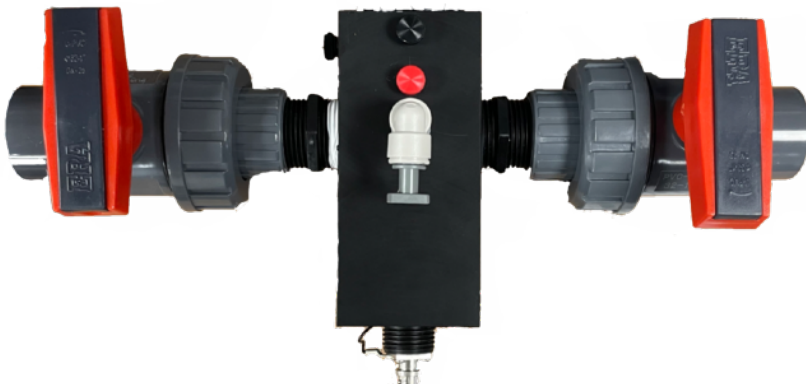

The Micrometrix® SCM features a Patented Wear Resistant Sensor design (US11,313,832). The Probe is “user serviceable” and eliminates many “wear factors” found in previous designs. The user can easily replace a disposable sleeve and piston within the sensor probe to restore accuracy and sensitivity. The Sensor also offers multi-mode operation for Self-testing, Calibration and Cleaning. Micrometrix® SCMs have proven to offer years of reliable and trouble-free service.

Patented

Benefits

- ▶ Chemical Savings
- ▶ Maintain Water Quality
- ▶ Early Warning Protection
- ▶ Prevent Upsets
- ▶ Optimize Treatment
- ▶ Reduce Residuals
- ▶ Easily Retrofitted



770.271.1330

micrometrix.com

contact@micrometrix.com

© 2022 Micrometrix®

All rights reserved

Engineering Specifications

The detector shall be a complete streaming current measurement instrument for continuous monitoring and control of coagulant dosage to assist in optimizing the water or wastewater treatment process.

The instrument shall be a single module with integrated sensor and shall operate on 110VAC power or 230VAC (optional) or 24VDC (optional).

The sensor shall receive a sample of treated water at a flow rate of 1~4 liters per minute. The sensor shall have a sample inlet and outlet of 1" FNPT. The sample probe shall be connected with a thumbscrew for easy removal without the use of tools for inspection or service. The probe housing shall use a disposable Teflon™ sleeve, which may be replaced independently of the electrodes. The upper and lower electrode shall be independently replaceable to facilitate easy servicing of the probe. The Sensor shall include two (2) spare probe piston / sleeves. Non-serviceable sensors and probe assemblies are not acceptable.

The detector shall be housed in a non-metallic NEMA 4x housing suitable for mounting outdoors. The enclosure shall have a facility to use a lock, or tamper-resistant device, to prevent unauthorized use.

The transmitter shall provide a 4~20mA output of the streaming current value rated at 600 ohms. The transmitter shall have control functions for 1) zero adjustment 2) continuous sensor sensitivity adjustment 3) internal amplifier gain adjustment 4) self diagnostic flashing LED sensor operation indicator. The adjustment controls shall be recessed and require the use of a trimmer tool to minimize tampering by unauthorized personnel.

The instrument shall be a Streaming Current Detector Model SCD-T as manufactured by Micrometrix® Corporation.

Specifications	Model SCD-T
Measurement	Streaming Current
Power	110 VAC / 230VAC (Optional) / 24 VDC (Optional)
Range	-1000 to +1000 mV
Accuracy	0.1%
Display Type	N/A
Flow Rate	1 ~ 4 Liter/Min (Standard) or 1 ~ 40 LPM (Optional)
Connection Type	1" FNPT inlet/outlet
Response Time	1 Second
Self Diagnostic	Sensor LED
Probe Materials	Delrin, 316 SS, PTFE
Outputs	4~20mA, -10 ~ +10 V, 0~10V
Communication	Modbus (with optional controller)
Alarms	N/A
Zero Adjust	Full Range
Enclosure	NEMA 4x, IP 65
Mounting Holes	11.0" x 6.00"
Weight	20 lbs , 9 kg

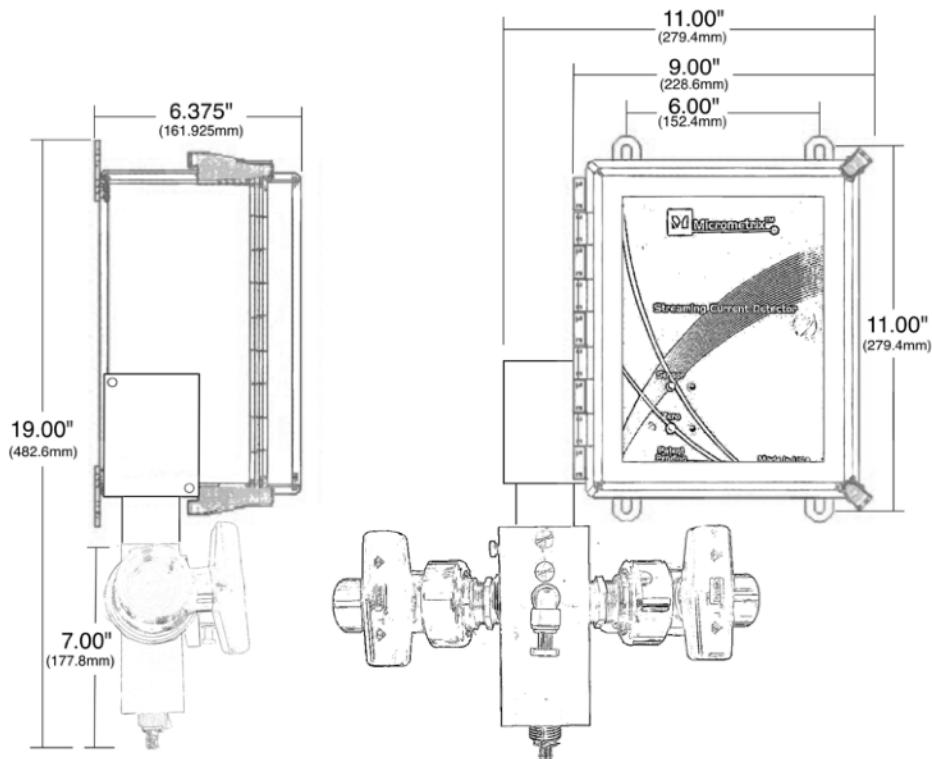

770.271.1330

micrometrix.com

contact@micrometrix.com

© 2022 Micrometrix®

All rights reserved