

## Model SCD-W610

### STREAMING CURRENT DETECTOR/ CONTROLLER

#### Features

- ▶ Pre-mounted
- ▶ Pre-wired
- ▶ 4~20mA Outputs
- ▶ NEMA Enclosures
- ▶ Serviceable Sensor
- ▶ Zero Offset Function
- ▶ Sensitivity Adjustment

### *Precise Coagulant Dose Control for Water Treatment*



\*Shown with optional self-cleaning

#### Sensor Advantage



The Micrometrix<sup>®</sup> SCM features an improved sensor design to provide years of trouble free service. The sensor probe is “user serviceable”. The user can easily replace a disposable sleeve and piston within the sensor probe to restore accuracy and sensitivity. This approach drastically reduces the cost of ownership of an SCM.

Patented

#### Benefits

- ▶ Chemical Savings
- ▶ Maintain Water Quality
- ▶ Early Warning Protection
- ▶ Prevent Upsets
- ▶ Optimize Treatment
- ▶ Reduce Residuals
- ▶ Easily Retrofitted



770.271.1330

[micrometrix.com](http://micrometrix.com)

[contact@micrometrix.com](mailto:contact@micrometrix.com)

© 2022 Micrometrix<sup>®</sup>

All rights reserved

## Engineering Specifications

The instrument shall be a fully self-contained Streaming Current Detector/Controller for continuous detection and control of coagulation/charge measurement for water, wastewater or industrial treatment processes.

The SCD and Controller shall be pre-mounted on a back panel for for ease of wall or control panel installation. The SCD and Controller shall be pre-wired and operate on 110VAC power or 230VAC (optional).

The sensor shall receive a sample of treated water at a flow rate of 1~4 liters per minute ( 1~10 GPM high flow optional). The sensor shall have a sample inlet of 3/4" and outlet of 1" barb style fitting. The sample probe shall be connected with a thumbscrew for easy removal without the use of tools for inspection or service. The probe housing shall use a disposable Teflon™ sleeve, which may be replaced independently of the electrodes. The upper and lower electrode shall be independently replaceable to facilitate easy servicing of the probe. The Sensor shall include two (2) spare probe piston / sleeves. Non-serviceable sensors and probe assemblies are not acceptable.

The SCD/Controller shall be housed in a non-metallic NEMA 4x enclosures suitable for mounting outdoors. The enclosures shall have a facility to use a lock, or tamper- resistant device, to prevent unauthorized use.

The SCD/Controller shall provide a 4~20mA outputs of the streaming current value and PID control signal output. The SCD/ Controller shall have control functions for 1) zero adjustment 2) continuous sensor sensitivity adjustment 3) internal amplifier gain adjustment 4) self diagnostic flashing LED sensor operation indicator. The adjustment controls shall be recessed and require the use of a trimmer tool to minimize tampering by unauthorized personnel.

The instrument shall be a Streaming Current Detector/Controller Model SCD-W610 as manufactured by Micrometrix® Corporation.

Specifications	Model SCD-T
Measurement	Streaming Current
Power	110 VAC / 230VAC (Optional)
Range	-1000 to +1000 mV
Accuracy	0.1%
Display Type	Color Touchscreen
Flow Rate	1~ 4 Liters/Min (Standard) or 1~ 10 GPM (Optional)
Connection Type	3/4" Barb Inlet 1" Barb Outlet
Response Time	1 Second
Self Diagnostic	Sensor LED
Probe Materials	Delrin, 316 SS, PTFE
Outputs	4~20mA, -10 ~ +10 V, 0~10V
Communication	Modbus (Optional)
Alarms	High Alarm, Low Alarm, Fault
Zero Adjust	Full Range
Enclosure	NEMA 4x, IP 65
Mounting Holes	22.0" x 10.00"
Weight	29 lbs , 13 kg

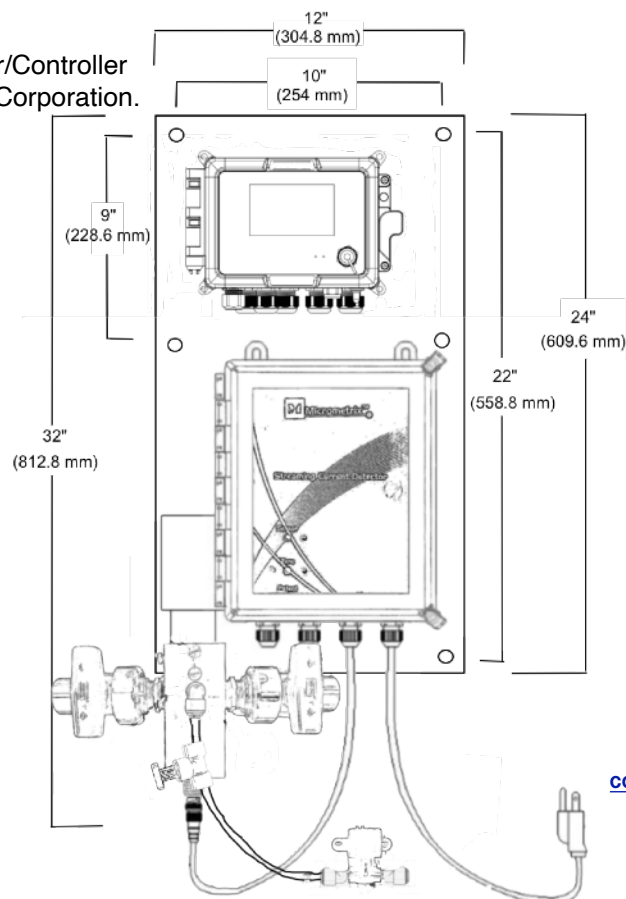

770.271.1330  
[micrometrix.com](http://micrometrix.com)  
[contact@micrometrix.com](mailto:contact@micrometrix.com)

© 2022 Micrometrix®  
 All rights reserved